

◆ C型钢电缆滑轨滑车

C-TRACK & CABLE TROLLEYS  
C30-C32-C40-C63



Mobile Electrification System  
**KOMAY**<sup>®</sup>

## C 型钢轨道/C-tracks

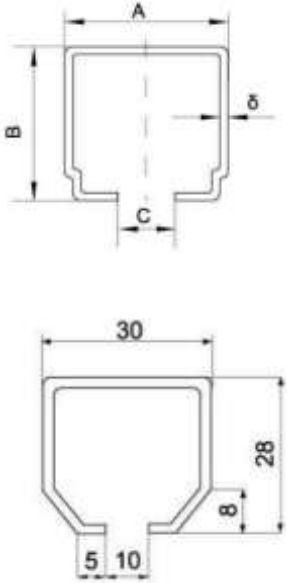

型号/Type	C32*30*5	C40*40*2.0	C63*63*4.0	C30*28*1.5
产品编码 Cat.-NO	710116*	720116*	750116*	700116*
材质/Material	Galvanized steel/镀锌钢(热镀锌处理, C63 系列外)			
重量/Weight Kg/m	1.19	2.00	5.98	1.03
轨道参数/Technical data				
A	32	40	63	30
B	30	40	63	28
C	12	13	18	10
δ	1.5	2.0	4.0	1.5
悬吊间距/Spacing	所能承受的最大负载/Max. Cable Load			
1.5m	89kg	188kg	503kg	70kg
2.0m	51kg	103kg	425kg	36kg
2.5m	39kg	73kg	302kg	22kg
3.0m	23kg	49kg	195kg	-
4.0m	-	28kg	85kg	-

\*根据需要在末尾填上定尺要求, 标准尺寸为 6 米, 也可提供 4 米/支的。

Standard Length: 6m, other lengths on quest.

## 概述/General

电缆滑车是一种理想的物流供电系统, 适用于室内外, 多尘, 多灰, 温差较大, 环境要求较低, 运行平稳。

科美滑线的电缆滑车轴承为球面接触, 使小车的移动灵活、稳固、均匀, 故障率极低。扁电缆及圆电缆均能安装使用, 并在滑线上装有缓冲装置及电缆保护装置。

目前, 电缆滑车广泛应用于各种通用桥, 门式起重机, 电动葫芦自行小车, 仓库, 船厂, 码头等起重设备的移动供电。

KOMAY Festoon Systems support conductor cables(flat or round) and hoses (hydraulic and pneumatic application for delivering power & control to mobile equipment in a safe, efficient and maintenance free method.

The cable trolleys are well guided inside their C-tracks and protected against humidity, dust and icing.

KOMAY cable trolleys not only deliver power and control to mobile equipment which has reciprocal motion but also support large quantities of data cables including optic fibers traveling independently from the mobile machinery. The relevant control carriers with and without push button lifting are also shown in this catalog.

## 技术参数/Technical data

Travel Speed	<120m/min
Temperature	-40℃—+125℃
Cable Load	<120kg

Travel Speed	Cable loop depth
Max. 35 m/ min	>0.3m
35-50 m/min	<0.8m
50-80 m/min	>0.8m

### 牵引首车/Towing Trolley (32)



C32 SC-75



C32SC-70



Type	C32SC-75	C32SC-70
Wheels	Ball bearing, hardened, galvanized Temperature resistance Lub. Grease of wheel:-30°C to +125°C Traveling Speed: ca. 160m/min.	
Material	Carrier body: steel, galvanized Support saddle: steel, galvanized Bumper: Neoprene Dowel: Brass Hardware: galvanized Temperature resistance: -30°C to +100°C	
Max.cable load	max.25 kg per carrier	max.22 kg per carrier
Dim.of Cable (mm)	max. 75W×32δ	max. 70W×32
Weight(kg)	0.59/0.52	0.55
Cat.-NO.	711101/711102	711105

### 固定尾车/End Trolley (32)



C32EC-75

It can be used for C32/C40 C-Track.



C32EC-70

Type	C32EC-75	C32EC-70
Material	Carrier body: steel, galvanized Support saddle: steel, galvanized Dowel: steel, galvanized Hardware: galvanized	
Max.cable load	max.25 kg per carrier	max.22 kg per carrier
Dim.of Cable (mm)	max. 75W×32δ	max. 70W×32δ
Weight(kg)	0.37/0.30	0.31
Cat.-NO.	711301/711302	711305

## 中间滑车/Middle Trolley(C32)



Type	C32MC-75	C32MC-70
Wheels	Ball bearing, hardened, galvanized Temperature resistance Lub. grease of wheel:-30℃to+125℃ Traveling Speed: ca. 160m/min.	
Material	Carrier body: steel, galvanized Support saddle:steel, galvanized Bumper:Neoprene Dowel: Brass Hardware: galvanized Temperature resistance:-30℃to+100℃	
Max.cable load	Max.30 kg per carrier	Max.25 kg per carrier
Dim.of Cable (mm)	max. 75W×32δ	max. 75W×32δ
Weight(kg)	0.41	0.32
Cat.-NO.	711101    711102(R=50,ABS)	711205

## 塑料中间滑车/Plastic Middle Trolley

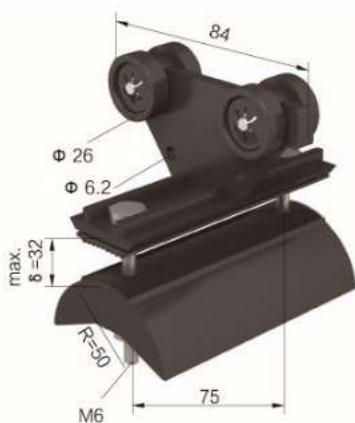

Type	C32PMC-70
Wheels	Wheel: nylon Temperature resistance Lub. grease of wheel:-30℃to+80℃ Traveling Speed: ca. 120m/min.
Material	Carrier body: ABS Support saddle: ABS Bumper:Neoprene Dowel: steel , galvanized Hardware: galvanized Temperature resistance:-30℃to+80℃
Max.cable load	Max.8 kg per carrier
Dim.of Cable (mm)	max. 70W×32δ
Weight(kg)	0.14
Cat.-NO.	711215



## 圆电缆滑车/Trolley for Round Cable

牵引首车/Towing Trolley C32RST



Type	C32RST-30	C32RST-40
Wheels	Ball bearing, hardened, galvanized Temperature resistance Lub. grease of wheel: -30°C to +125°C Traveling Speed: ca. 120m/min.	
Material	Carrier body: steel, galvanized Support saddle: galvanized steel or aluminum Dowel: Brass or steel, galvanized Hardware: galvanized Temperature resistance: -30°C to +125°C	
Max.cable load	Max.20 kg per carrier	Max.25 kg per carrier
Dim.of Cable (mm)	max.D=Φ 30mm	max.D=Φ 40mm
Weight(kg)	0.73	0.75
Cat.-NO.	711130	711140



固定尾车/End Trolley C32RET

Type	C32RET-30	C32RET-40
Material	Carrier body: steel, galvanized Support saddle: galvanized steel or aluminum Dowel: Brass or steel, galvanized Hardware: galvanized Temperature resistance: -30°C to +125°C	
Max.cable load	Max.20 kg per carrier	Max.25 kg per carrier
Dim.of Cable (mm)	max.D=Φ 30mm	max.D=Φ 40mm
Weight(kg)	0.27	0.29
Cat.-NO.	711330	711340

中间滑车/Middle Trolley C32 RMT



Type	C32RMT-30	C32RMT-40
Wheels	Ball bearing, hardened, galvanized Temperature resistance Lub. grease of wheel: -30°C to +125°C Traveling Speed: ca. 120m/min.	
Material	Carrier body: steel, galvanized Support saddle: galvanized steel or aluminum Dowel: Brass or steel, galvanized Hardware: galvanized Temperature resistance: -30°C to +125°C	
Max.cable load	Max.20 kg per carrier	Max.25 kg per carrier
Dim.of Cable (mm)	max.D=Φ 30mm	max.D=Φ 40mm
Weight(kg)	0.36	0.38
Cat.-NO.	711230	711240

中间滑车/Middle Trolley C32 RMC

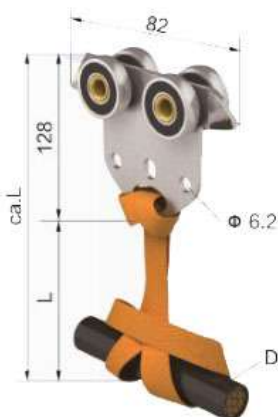

Type	C32RMC
Wheels	Ball bearing, hardened, galvanized Temperature resistance Lub. grease of wheel: -30°C to +125°C Traveling Speed: ca. 120m/min.
Material	Carrier body: steel, galvanized Clamp: steel, galvanized ( available) Sling: Nylon Dowel: Brass or steel, galvanized
Max.cable load	Max.22 kg per carrier
Dim.of Cable (mm)	max.D=Φ 50mm/ D=Φ 80mm/D=Φ 160mm
Weight(kg)	0.29
Cat.-NO.	712206(D=50,L=160) 712208(D=80,L=190) 712210(D=160,L=270)



### C32 系列吊夹/Hanger C32 DJ for C-track Support Bracket

C32DJ-1

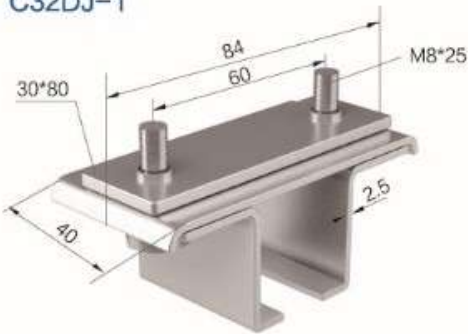

C32DJ-2

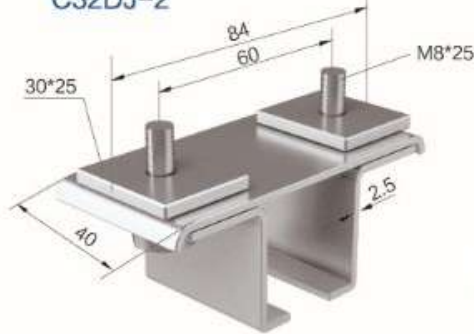

Type	Weight kg	Material	Cat.-No.
C32DJ-1	0.22	Galvanized steel	714101
C32DJ-2	0.22	Galvanized steel	714102

### C32 系列吊夹/Hanger C32 DJ For Angel steel support Bracket

C32DJ-5

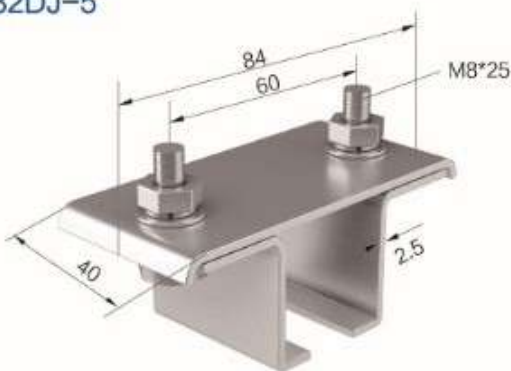

Type	Weight kg	Material	Cat.-No.
C32DJ-5	0.20	Galvanized steel	714105

### C32 系列接头/Joint Clamp C32 JT

C32JT-1

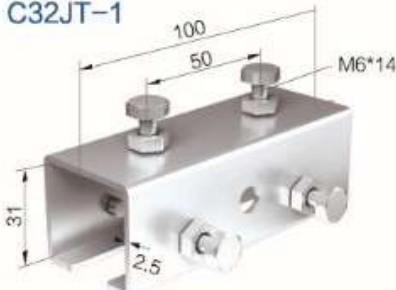

C32JT-2



C32JT-3



Type	Weight kg	Material	Order-No.
C32JT-1	0.28	Galvanized steel	713401
C32JT-2	0.27	Galvanized steel	713402
C32JT-3	0.46	Galvanized steel	713403

### C32 系列端帽/End Cap C32 DM

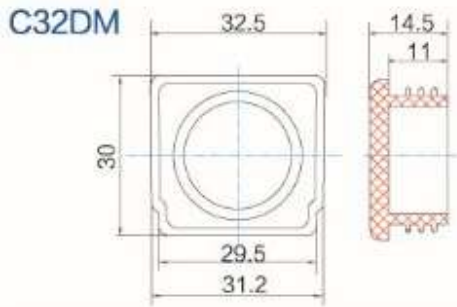

Type	Weight kg	Material	Order-No.
C32DM	0.005	Plastic	713708

### C32 系列线卡/Cable clip C32 XK

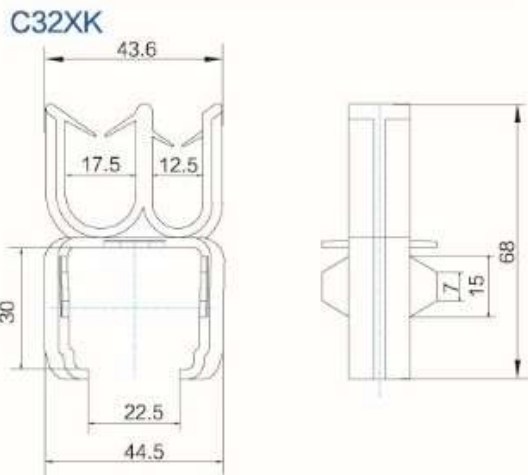

Type	Weight kg	Material	Order-No.
C32XK	0.02	Plastic	713718

### C32 系列端阻/End Stop C32 DZ

Could be used for C32/C40 C-Track.

C32DZ-1

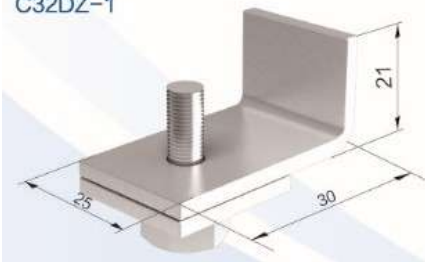

Type	Weight kg	Material	Order-No.
C32DZ	0.05	Galvanized steel	713702

### C32 系列端阻/End Stop C32 DZ

Could be used for C32/C40 C-Track.



Type	Weight kg	Material	Order-No.
C32BDZ	0.05	Galvanized steel	713705



### 中间滑车/Middle Trolley(C30)

C30MC-60

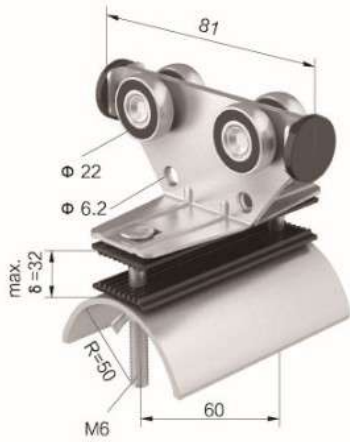

### 牵引首车/Towing Trolley (C30)

C30SC-60



Type	C30MC-60	C32SC-60
Wheels	Ball bearing, hardened, galvanized Temperature resistance Lub. grease of wheel:-30℃to+125℃ Traveling Speed: ca. 120m/min.	
Material	Carrier body: steel, galvanized Support saddle:steel, galvanized Bumper:Neoprene Dowel: steel galvanized Hardware: galvanized Temperature resistance:-30℃to+100℃	
Max.cable load	Max.20 kg per carrier	Max.20 kg per carrier
Dim.of Cable (mm)	max. 60W×32δ	max. 60W×32δ
Weight(kg)	0.28	0.53
Cat.-NO.	701201	701101

### 固定滑车/End Trolley(C30)

C30EC-60



Type	C30EC-60
Material	Carrier body: steel, galvanized Support saddle: steel, galvanized Dowel: steel, galvanized Hardware: galvanized
Max.cable load	max.20 kg per carrier
Dim.of Cable (mm)	max. 60W×32δ
Weight(kg)	0.30
Cat.-NO.	701301



### 塑料中间滑车/Plastic Middle Trolley

C30PMC-70



Type	C30PMC-70
Wheels	Wheel: nylon Temperature resistance Lub. grease of wheel: -30°C to +80°C Traveling Speed: ca. 120m/min.
Material	Carrier body: ABS Support saddle: ABS Bumper: Neoprene Dowel: steel, galvanized Hardware: galvanized Temperature resistance: -30°C to +80°C
Max.cable load	Max.8 kg per carrier
Dim.of Cable (mm)	max. 70W×32δ
Weight(kg)	0.13
Cat.-NO.	701215

### C30 系列吊夹/ Hanger C30DJ

for C-track Support Bracket

C30DJ-2

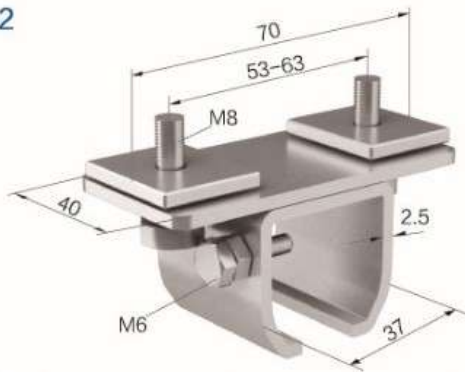

安装示例  
ready installed

Type	Weight kg	Material	Cat.-No.
C30DJ-2	0.21	Galvanized steel	704102

### C30 系列吊夹/Hanger C30DJ

for Angel steel Support Bracket

C30DJ-5



安装示例  
ready installed

Type	Weight kg	Material	Cat.-No.
C30DJ-5	0.15	Galvanized steel	704105

**C30 系列接头/Hanger C30JT**

C30JT-1

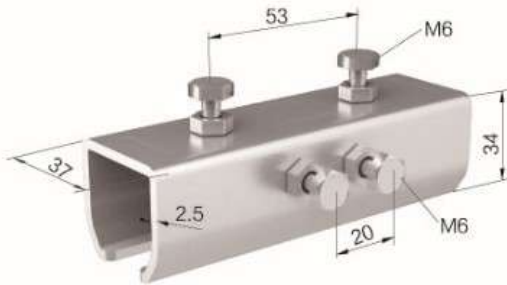
安装示例  
ready installed

Type	Weight kg	Material	Cat.-No.
C30DJ-1	0.28	Galvanized steel	703401

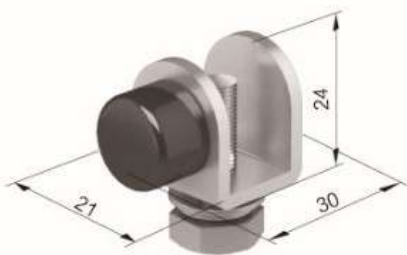
**C30 系列缓冲端阻/Bumper End Stop C30BDZ**安装示例  
ready installed

Type	Weight kg	Material	Cat.-No.
C30BDZ	0.05	Galvanized steel	703705

**C30 系列端帽/End Cap C30DM**

C30DM

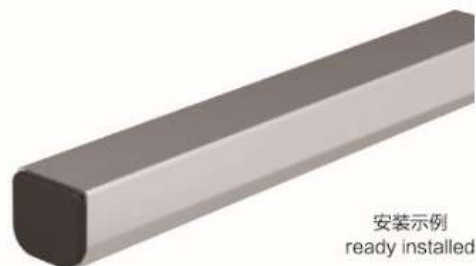
安装示例  
ready installed

Type	Weight kg	Material	Cat.-No.
C30DM	0.005	Plastic	703701

## 中间滑车/Middle Trolley (C40)

## 牵引首车/Towing Trolley (C40)

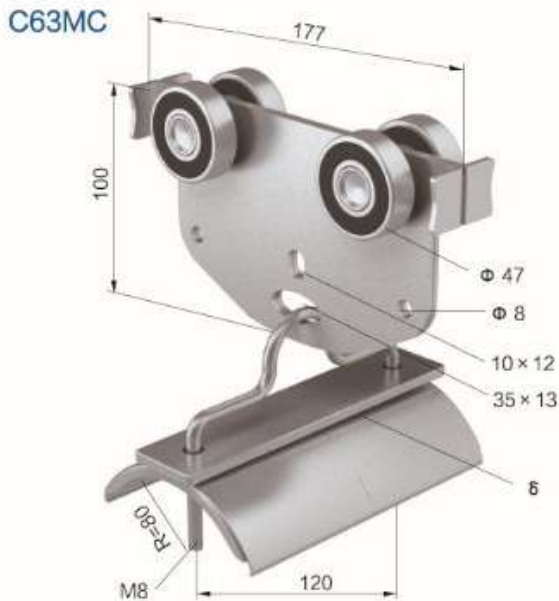

Type	C40MC	C40SC
Wheels	Ball bearing, hardened, galvanized Temperature resistance Lub. grease of wheel: -30°C to +125°C Traveling Speed: ca. 160m/min.	
Material	Carrier body: steel, galvanized Support saddle: steel, galvanized or ABS Bumper: Neoprene Dowel: steel galvanized Hardware: galvanized Temperature resistance: -30°C to +100°C (80°C, saddle ABS)	
Max.cable load	Max.35 kg per carrier	Max.35 kg per carrier
Dim.of Cable (mm)	max. 75W×325	max. 75W×325
Weight(kg)	0.52	0.65
Cat.-NO.	721201,721202	721101,721102

## 圆电缆滑车/Trolley for Round Cable

C40RMC



Type	C40RMC
Wheels	Ball bearing, hardened, galvanized Temperature resistance Lub. grease of wheel: -30°C to +125°C Traveling Speed: ca. 100m/min.
Material	Carrier body: steel, galvanized Sling: Nylon Dowel: steel, galvanized Hardware: galvanized
Max.cable load	Max.28 kg per carrier
Dim.of Cable (mm)	D=Φ 50mm/ D=Φ 80mm/D=Φ 160mm
Weight(kg)	0.33
Cat.-NO.	722206 (D=50,L=160) 722208 (D=80,L=190) 722210 (D=160,L=270)



### C40 系列吊夹/ Hanger C40 DJ for C-track Support Bracket

C40DJ-1

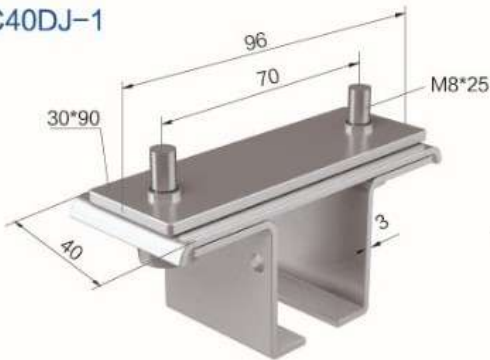

C40DJ-2

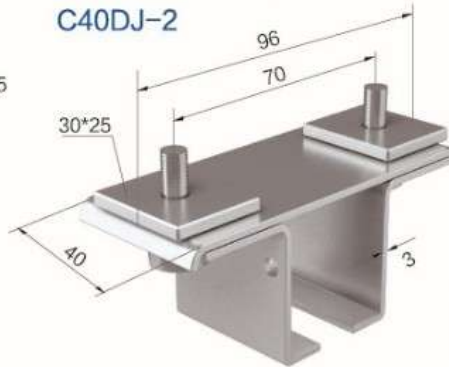

安装示例  
ready installed

Type	Weight kg	Material	Cat.-No.
C40DJ-1	0.30	Galvanized steel	724101
C40DJ-2	0.28	Galvanized steel	724102

### C40 系列吊夹/ Hanger C40 DJ

用于角钢安装支架/for Angle steel Support Bracket

C40DJ-5



安装示例  
ready installed

### C40 系列端帽/End Cap C40DM

C40DM

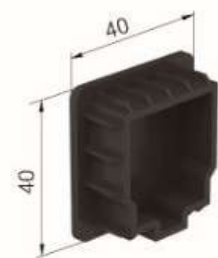

Type	Weight kg	Material	Cat.-No.
C40DJ-5	0.22	Galvanized steel	724105

Type	Weight kg	Material	Cat.-No.
C40DM	0.01	Plastic	723701

### C40 系列接头/Joint Clamp C40JT

C40JT-2



安装示例  
ready installed

C40JT-3

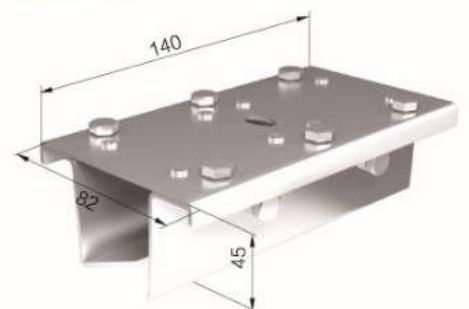

Type	Weight kg	Material	Cat.-No.
C40JT-2	0.32	Galvanized steel	723402
C40JT-3	0.45	Galvanized steel	723403



## 中间滑车/Middle Trolley (C63)

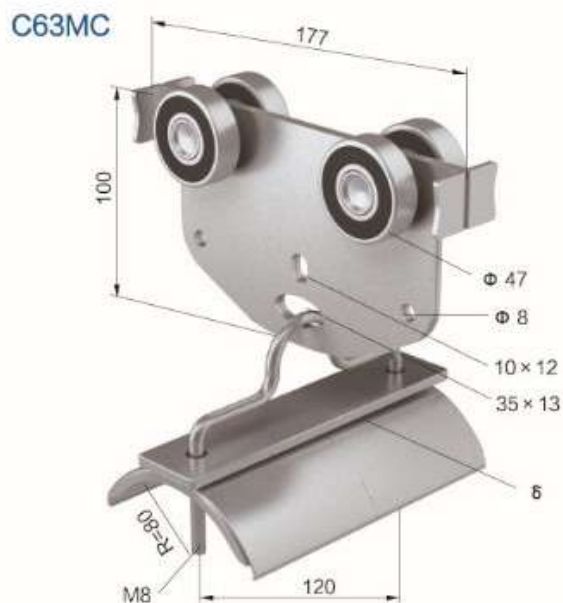

## 牵引首车/Towing Trolley (C63)



Type	C63MC	C63SC
Wheels	Ball bearing, hardened, galvanized Temperature resistance Lub. grease of wheel: -30°C to +125°C Traveling Speed: ca. 160m/min.	
Material	Carrier body: steel, galvanized Support saddle: steel, galvanized Dowel: steel galvanized Hardware: galvanized Temperature resistance: -30°C to +100°C	
Max.cable load	Max.65 kg per carrier	Max.65 kg per carrier
Dim.of Cable (mm)	max. 120W×40δ	max. 120W×40δ
Weight(kg)	1.95	2.30
Cat.-NO.	751201	751101

## 固定尾车/End Trolley (63)



Type	C63EC
Material	Steel ,galvanized
Max.cable load	max.65 kg per carrier
Dim.of Cable (mm)	max. 120W×40δ
Weight(kg)	1.15
Cat.-NO.	751301

### C63 系列吊夹/ Hanger C63 DJ

C63DJ

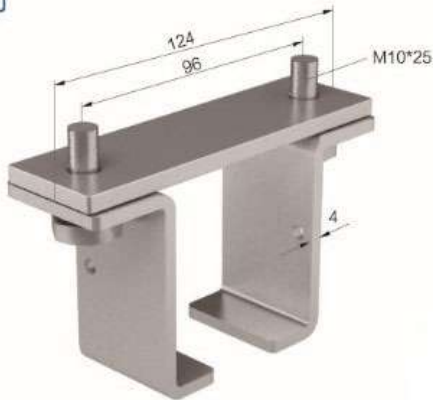

Type	Weight kg	Material	Cat.-No.
C63DJ	0.45	Galvanized steel	754102

### C63 系列接头/ Hanger C63 JT

C63JT



Type	Weight kg	Material	Cat.-No.
C63JT	0.72	Galvanized steel	753402

### C63 系列端阻/ Hanger C63 DZ

C32DZ-1

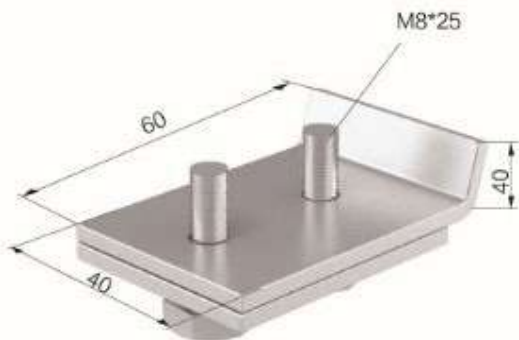

Type	Weight kg	Material	Cat.-No.
C63DZ	0.25	Galvanized steel	753702